



All of our recipes were tested with Gold Medal All Purpose Flour. Why trust your recipes to anything else?



And if you want these recipes to be better, it better be Bertolli.

Popeil Pasta Products, Inc.  
AGOURA HILLS, CA

# Popeil's AUTOMATIC Pasta Maker™



# RECIPES AND INSTRUCTIONS



# Important Safeguards

When using electrical appliances, basic safety precautions should always be taken, including the following:

1. Read all instructions before using the machine.
2. To protect against electrical hazards, do not immerse main body, motor assembly or other electrical parts in water or other liquid.
3. Close supervision is necessary when appliance is used by or near children.
4. Unplug machine from outlet when not in use, before putting on or taking off parts and before cleaning.
5. Avoid contacting moving parts. Keep hair and jewelry away from machine grates.
6. Do not operate any appliance with a damaged cord or plug after the appliance malfunctions or is dropped or damaged in any manner. Return the appliance to Popeil Pasta Products, Inc. for examination, repair or electrical or mechanical adjustment.
7. The use of attachments not recommended or sold by Popeil Pasta Products, Inc. may cause hazards.
8. Do not use outdoors.
9. Do not let cord hang over edge of table or counter or touch hot surfaces.
10. Keep hands, hair, jewelry, clothing, as well as spatulas and other utensils or foreign objects away from the container while Pasta Maker is running to reduce the risk of injury to person and/or damage to the machine.
11. Remove the lid, mixing blade, front housing and mixing bin from motor unit before washing the assembly.
12. Always operate machine with cover in place.
13. Be sure to turn switch to OFF position after each use. Make sure the motor stops completely before disassembling any section of the machine.
14. Use only on 120-volt AC outlets.
15. Do not attempt to defeat the cover interlock mechanism.
16. Do not open lid until blades have completely stopped.
17. Do no use appliance for other than intended use.

FOR HOUSEHOLD USE ONLY

## SAVE THESE INSTRUCTIONS

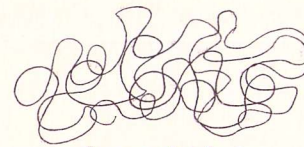

Angel Hair



Vermicelli

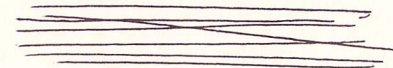

Spaghetti

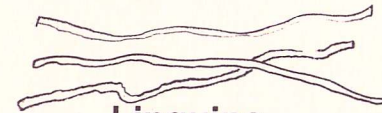

Linguine



Fettuccine

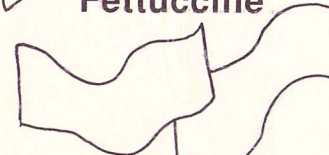

Tagliatelle

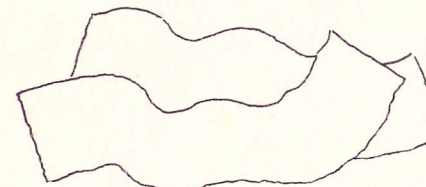

Pappardelle

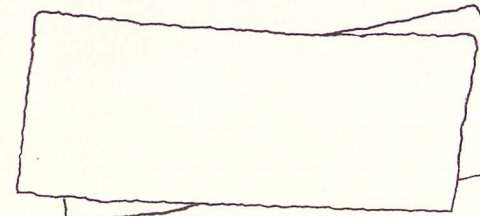

Lasagne



Rotini



Fusilli



Macaroni

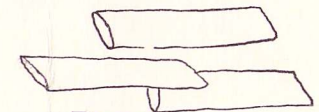

Penne



Rigatoni

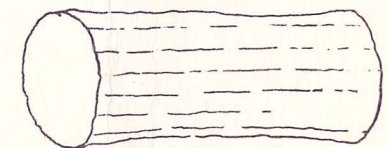

Manicotti



Gnocchi



Shells



Ravioli

## ADDITIONAL SHAPING DIES

Additional dies are available from our Customer Service Department for \$9 each. (See Order Form).

*Cleaning tip: After use, wipe the face of your die and let it dry out. Then the dough easily falls out.*

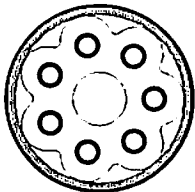

Penne

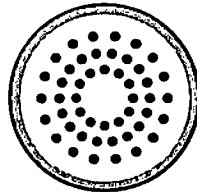

Oriental Noodle

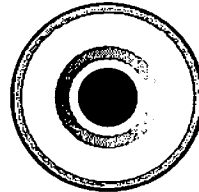

Bagel & Meatball

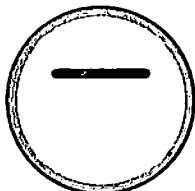

Rugala

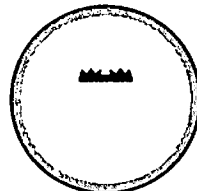

Small Cookie

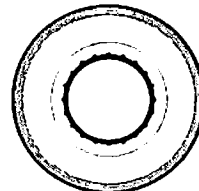

Manicotti

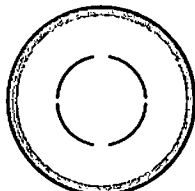

Pappardelle

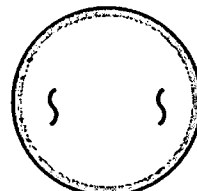

Rotini

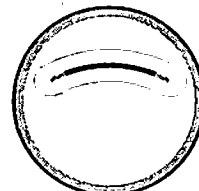

Shell

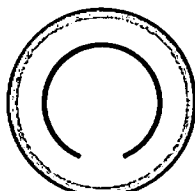

Pastry

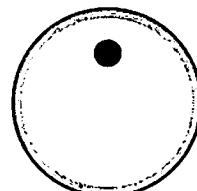

Breadstick

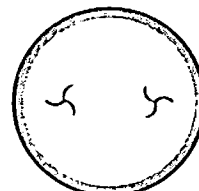

Fusilli

# Poppeil AUTOMATIC Pasta Maker™

Congratulations. You have the finest pasta maker ever made for home use. This machine has been designed to give years of service. It is very efficient and easy to use once you understand how it works. So please take the time to read the instructions and watch the Instructional Video before using your Poppeil Automatic Pasta Maker™.

## CONTENTS

- 2 Cautions
- 3 Assembly
- 7 About Fresh Pasta
- 8 Pasta Making Tips
- 9 How to Make Fresh Pasta
- 11 Cleaning
- 12 Troubleshooting
- 13 Recipes
- 28 Warranty
- 31 Spanish Instructions
- 39 Pasta Shaping Dies

Copyright © 1993, 1994, 1995 by Poppeil Pasta Products, Inc. All rights reserved. Poppeil™ Automatic Pasta Maker™ is a trademark owned by Poppeil Pasta Products, Inc. No part of this book may be reproduced in any manner whatsoever without written permission from the publisher, Poppeil Pasta Products, Inc. Patents Pending.

## CAUTIONS

- Make sure dry and liquid ingredients are completely mixed before switching Popeil's Pasta Maker to EXT (extrude). **Never try to extrude pasta dough which is too dry.**
- Always add dry ingredients to mixing bin and close lid before slowly adding liquid ingredients.
- With some pasta dough, such as chocolate, the round bearing directly behind the kneading screw may squeak. If this happens, you can oil the bearing by smearing it with vegetable oil.
- Do not put knife or anything through the openings on lid. They are for adding liquid and/or flour only.
- After MIX, always switch to OFF and let the motor completely stop before switching to EXT (extrude).
- The motor can produce a flash of light when being switched from MIX to EXT (extrude). This is normal.
- Do not block the vent holes in front of the pasta maker. Avoid getting flour or anything in the front vent holes. If flour should get in the vent holes: Unplug the machine and tip the Pasta Maker all the way forward until the vent holes are pointing straight down, and gently shake the Pasta Maker up and down over a trash can to remove any flour.
- Don't use detergents to wash the motor housing of your pasta maker. Use a cloth dampened with water.
- Keep your Pasta Maker away from heat sources such as hot stove burners and oven tops when the oven is on.
- Make sure your Pasta Maker is properly and completely assembled before turning it on.
- If it is difficult to remove the front Locking Ring that holds the pasta die, switch the Pasta Maker to MIX for a few seconds. Then turn the machine OFF and use the wrench provided to loosen the Locking Ring.
- Noise = Power. This is a very powerful machine. Keep all hair, jewelry, clothing, spatulas and foreign articles away from it while in use.
- When turning the machine "OFF", be sure to wait until the blades have completely stopped before opening the lid.

## STANDARD SHAPING DIES

Twelve dies come with your machine. These give various shapes to the dough as it is forced through the die (extruded). Use them in the position shown here (name at bottom). Line up the six notches on the back of die with the six ridges on the face plate.

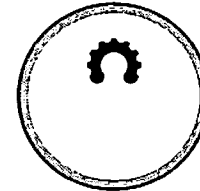

Gnocchi

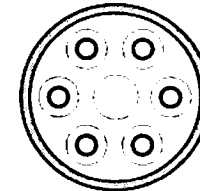

Macaroni

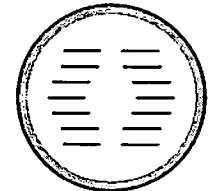

Tagliatelle

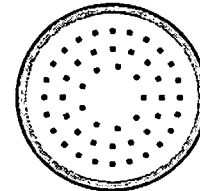

Vermicelli

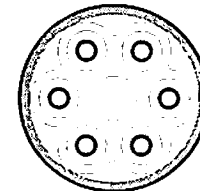

Rigatoni

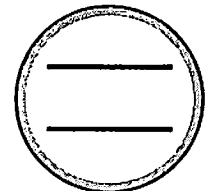

Lasagne

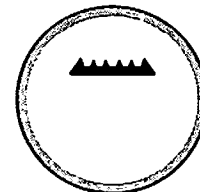

Cookie

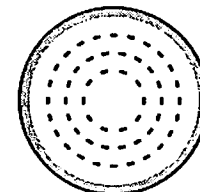

Linguini

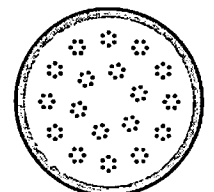

Angel Hair

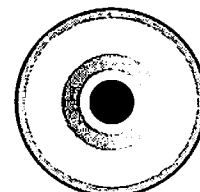

Small Bagel

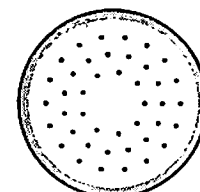

Spaghetti

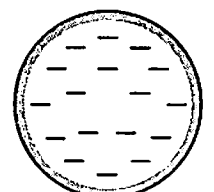

Fettuccine

## PRECAUCIONES

Cerciórese de que los ingredientes líquidos y sólidos estén completamente mezclados antes de mover el interruptor de su máquina Pasta Maker a la posición "EXT" (extraer empujando a través del molde). Nunca trate de sacar la pasta si está demasiado seca.

Siempre agregue los ingredientes sólidos al recipiente de mezclar y cierre bien la tapa antes de agregar lentamente los ingredientes líquidos.

Con algunos tipos de masa para pasta, tal como la pasta de chocolate, es normal que la máquina haga un ruido extraño. Si esto sucede, usted puede aplicar un poco de aceite vegetal sobre el eje.

Después de la posición "MIX", siempre mueva el interruptor a la posición de apagado "OFF" y deje que el motor pare completamente antes de pasar a la posición "EXT" (extraer empujando a través del molde.)

A veces el motor producirá una luz al pasar de "MIX" a la posición "EXT". Esto es normal.

No obstruya las entradas de aire situadas en la parte delantera de la máquina.

Evite que la harina o cualquier otro objeto penetre en las entradas de aire de la parte delantera de la máquina. En caso de que esto suceda, desconecte la máquina y volteela de manera que las entradas de aire estén directamente hacia abajo y sacuda suavemente la máquina Pasta Maker de arriba a abajo, sobre un cesto, para sacar la harina.

No use detergentes para lavar la cubierta del motor. Use un trapo húmedo para limpiarla.

Mantenga la máquina Pasta Maker alejada de superficies calientes tales como estufas y hornos, cuando estos estén encendidos.

Asegúrese que su máquina para hacer pasta esté correctamente ensamblada antes de activarse.

Si se le dificulta aflojar la tuerca de seguridad que sostiene el molde de la pasta, durante unos segundos coloque el botón de la máquina en la posición "MIX". Después ponga la máquina en la posición "OFF" y use la llave incluida para aflojar la tuerca de seguridad.

Ruido = Fuerza. Debido a la fuerza del motor, mantenga el cabello, joyería, ropa, espátulas y otros utensilios fuera del alcance de la máquina.

## ASSEMBLY

**Lid must be firmly latched  
or machine won't run.**

**To disassemble, remove lid first.**

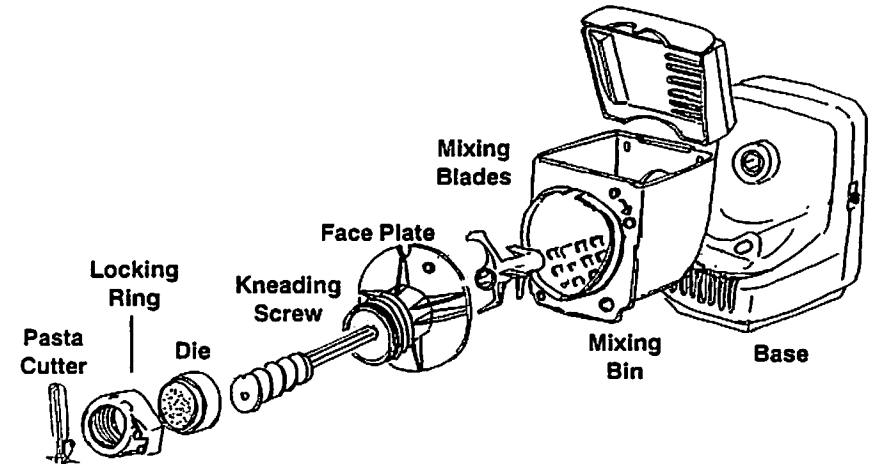

**Pasta Cutter**  
Used to cut the pasta at appropriate lengths.

**Locking Ring**  
Holds the pasta die in place.

**Pasta Die**  
Dough is pushed through to form pasta.

**Kneading Screw**  
Kneads the dough and forces it through the pasta die.

**Face Plate**  
Holds the kneading screw, die, locking ring.

**Mixing Blades**  
Mixes the dough, then pushes it forward during *extrusion* (pushing through a die).

**Base**  
Supports the mixing bin and contains the motor.

**Mixing Bin**  
Holds your pasta dough.

**Please read all instructions and cautions before operating this machine.**

We have designed this machine to make it easy for you to use (and clean) while making it powerful and efficient. It is the finest pasta maker available for home use today.

*Be creative and develop different kinds of pasta. Enjoy it and have fun.*

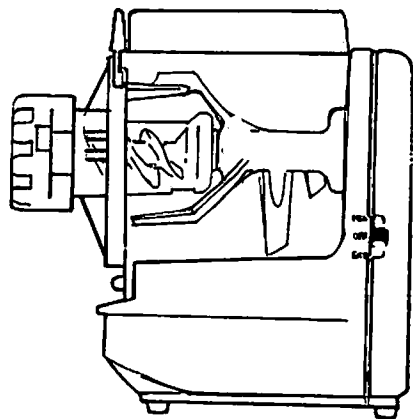

**Switch Delay**

Your unit comes equipped with a delay switch that takes a second to turn the motor on. This feature adds to the life and safety of your Pasta Maker.

**HOW TO ASSEMBLE**

Unplug machine and turn switch to OFF.

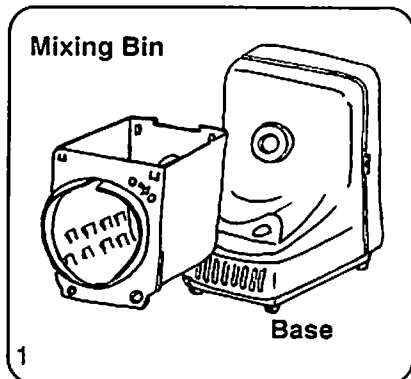

Place mixing bin firmly onto the base (all the way). The machine will not run if the mixing bin is not all the way back.

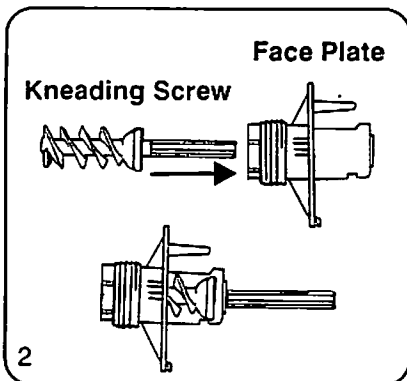

Put the kneading screw through the face plate all the way.

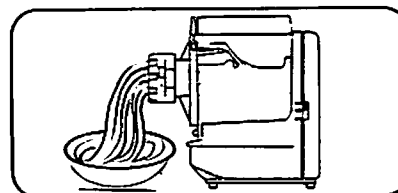

**Paso 7.** Ponga la máquina en la posición "EXT" y vea salir la pasta al frente. Córrela al tamaño deseado con el cortador de pasta.

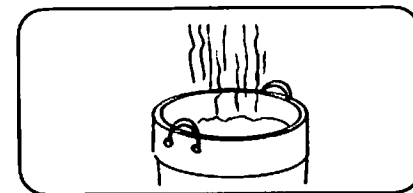

**Paso 8.** Hierva la pasta fresca por lo menos en 6 cuartos de agua. Cuélela y sírvala con salsa. Las formas más pequeñas sólo tardan del 1 a 2 minutos. NO LA HIERVA EN EXCESO.

**MEDIA RECETA** (de 2 a 4 porciones)

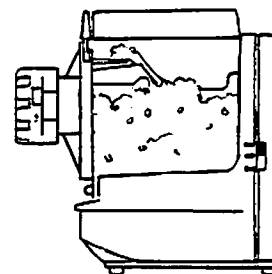
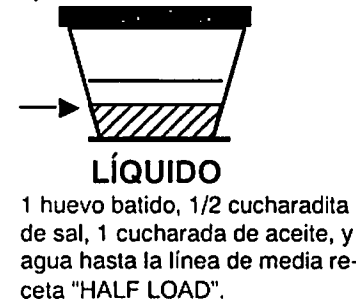

**Perfecta-**  
La mezcla perfecta tiene grumos pequeños. Es fácil obtener la mezcla correcta si se retiene un poco del líquido hasta ver como resulta la masa de la pasta (aproximadamente 1 minuto).

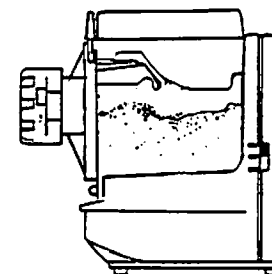

**Demasiado Seca-**  
Aún está grunulosa. Simplemente agregue líquido (agua o jugo) por cucharaditas mientras la máquina sigue mezclando. Vea los pequeños grumos.

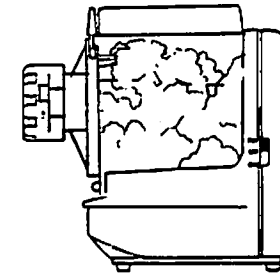

**Demasiado Acuosa-**  
Una bola grande y acuosa. Agregue más harina mientras la máquina sigue mezclando hasta que aparezcan los pequeños grumos. Tal vez tenga que parar la máquina y despegar la masa de las cuchillas.



# COMO HACER PASTA FRESCA

Le recomendamos que haga la mitad de la receta por lo menos las primeras 6 veces que haga pasta al estrenar su máquina.

Paso 1. Máquina apagada (OFF). Tapadera abierta.

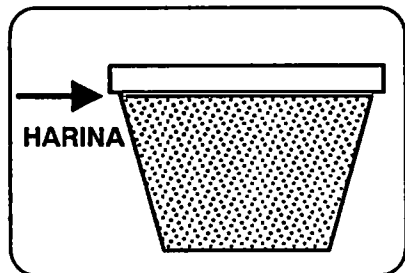

Paso 2. Con la taza medidora de pasta vierta 1 taza de harina en el recipiente de mezclar y cierre la tapadera.

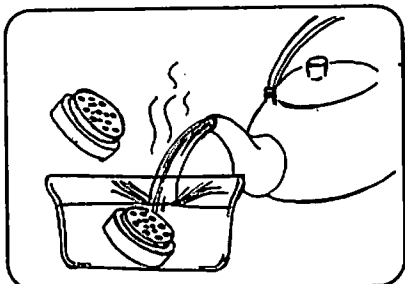

Paso 3. Seleccione el molde que desea usar para hacer pasta. Colóquelo en agua muy caliente durante un minuto.

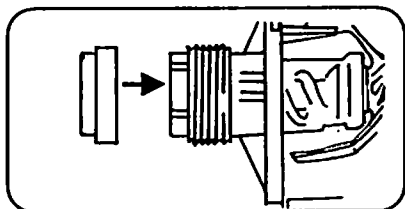

Paso 4. Coloque el molde caliente al frente de la máquina y fijelo con la tuerca de seguridad.

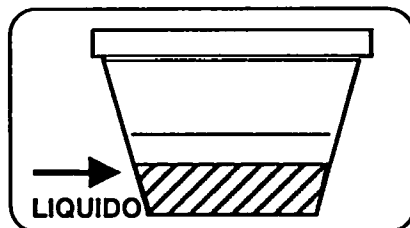

Paso 5. En la tasa para medir pasta, agregue: 1 huevo, 1/2 cucharadita de sal, 1 cucharada de aceite de olivo, agua (o jugo) hasta la marca que indica la mitad "HALF LOAD" (para media receta). Bata el huevo, aceite y el agua con un tenedor, o agítela vigorosamente teniendo cerrada la tapadera de la taza de medir pasta.

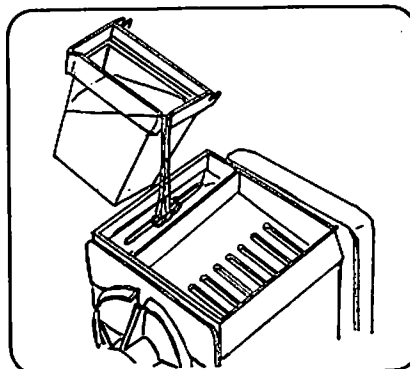

Paso 6. Ponga la máquina en la posición de Mezcla "MIX" y agregue lentamente el líquido por la ranura en la tapadera, mientras la máquina mezcla los ingredientes. Mézclelos de 1 a 2 minutos. La masa de la pasta debe estar mezclada uniformemente y con grumos pequeños. No debe parecer granulosa (demasiado seca) ni como una bola grande y húmeda (demasiada agua).

Paso 7. Apaque la máquina y deje que pare completamente. Nunca pase directamente de "MIX" a "EXT".

# ASSEMBLY

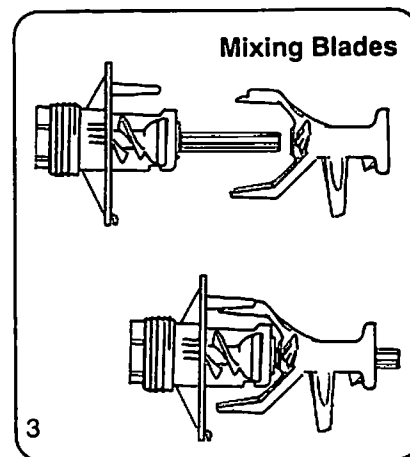

Slip the mixing blades onto the screw shaft. Note: The white arrow on the mixing blades lines up with the groove on the kneading screw shaft.

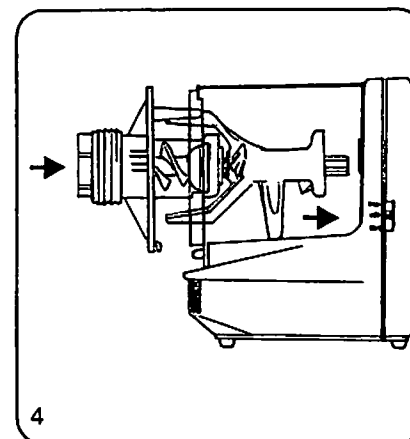

Insert the mixing assembly loosely into the mixing bin, with the shaft going into the hole in the base.

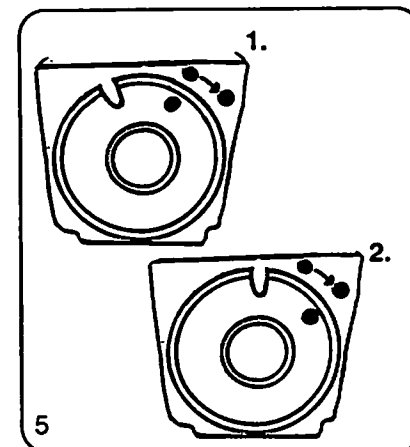

Line up the face plate dots. (position 1)  
Push the mixing assembly fully in, and turn the face plate to the right. (position 2)

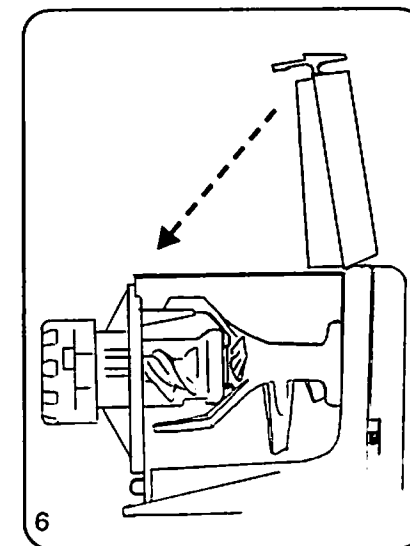

Place the lid on vertically and then close it down.

Note: The back tab on the lid goes into the slot on the base. The lid must be securely closed to operate the machine.

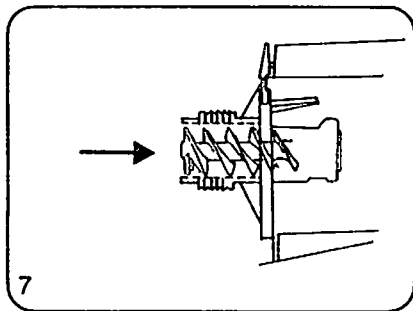

Be sure the kneading screw is all the way in.

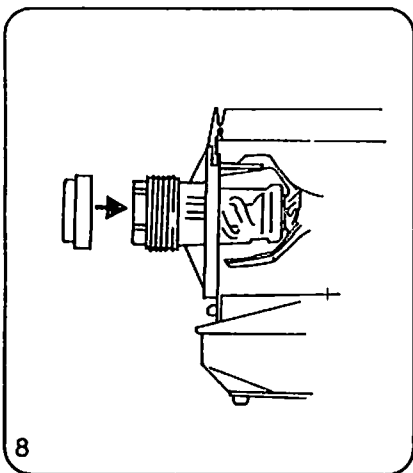

Select a pasta die, and slide it onto the front of the face plate, matching the 6 notches, and with the name of the pasta at the bottom of the die.

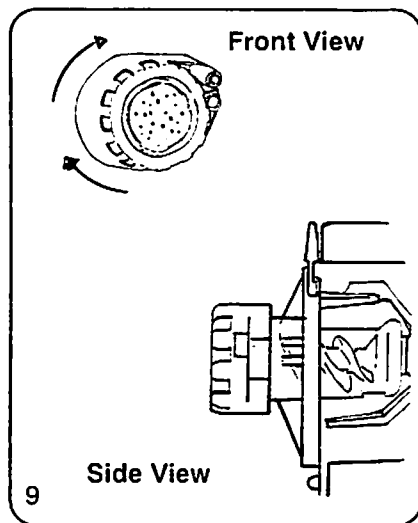

Screw the locking ring over the pasta die to secure it.

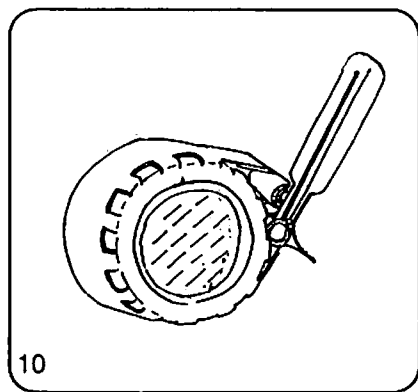

Snap the pasta cutter into one of the two holes - top hole is for raised dies (macaroni), the bottom hole is for regular dies. You're ready to make pasta!

Nota: La parte trasera de la tapadera entra en la ranura de la base. Cerciérese de que la tapa esté bien cerrada antes de operar la máquina.

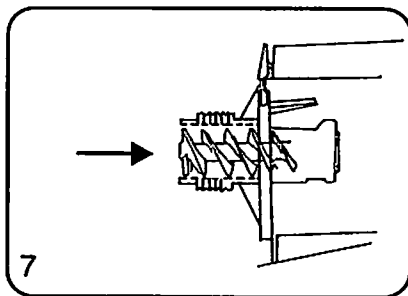

Cerciérese de que el tornillo de mezclar se haya introducido totalmente hasta el fondo.

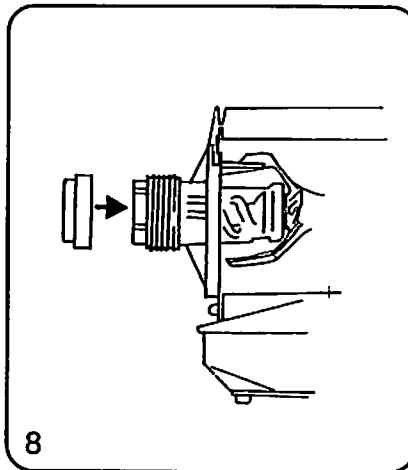

Seleccione un molde de pasta, y colóquelo frente a la placa frontal, colocando los 6 dientes en su lugar correspondiente y dejando el nombre de la pasta en la parte inferior del molde.

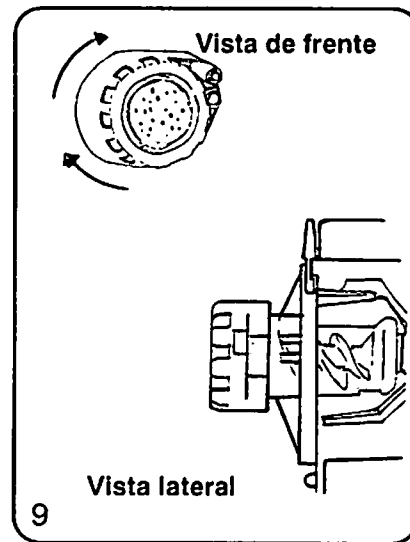

Enrosque la tuerca de seguridad sobre el molde de pasta para asegurarlo en la posición correcta.

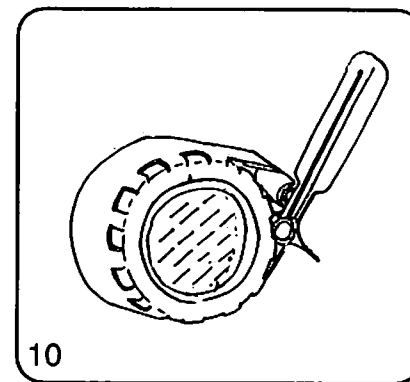

Meta a presión el cortador de pasta dentro de uno de los orificios: el orificio superior es para moldes gruesos (como para macarrones), el orificio inferior se usa para moldes de tamaño regular. ¡Ahora usted está lista para hacer pasta!



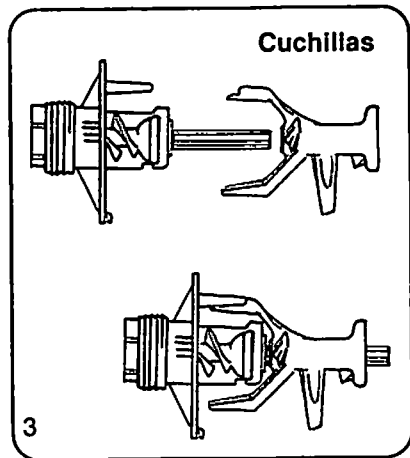

Coloque las **cuchillas mezcladoras** sobre el eje atornillador.

Nota: La flecha de las **cuchillas mezcladoras** se alinean con la ranura del eje del tornillo de mezclar.

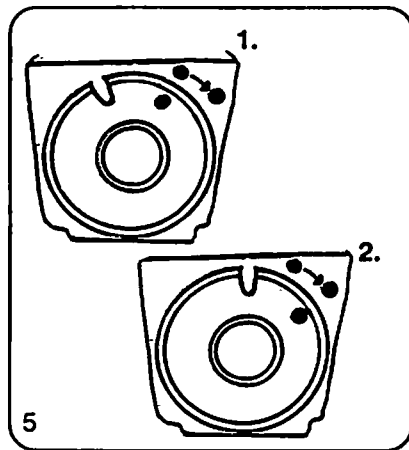

Alinee las marcas de la **placa frontal** (posición 1). Empuje el **ensamblaje de mezclar** completamente hasta el fondo y gire la **placa frontal** hacia la derecha (posición 2).

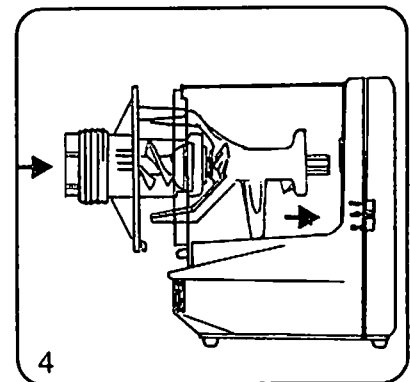

Coloque el **ensamblaje de mezclar** dentro del **recipiente de mezclar** y compruebe que el eje entre en el orificio hexagonal de la base.

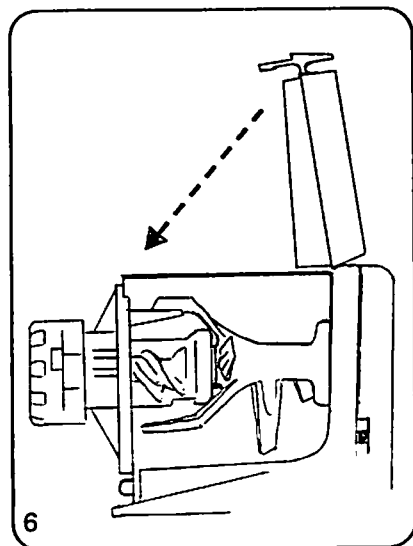

Coloque la **tapadera verticalmente** y ciérrela.

### Which Flour?

Many flours work well with your pasta maker. As well as gourmet pasta flours, we have tested the recipes with **Gold Medal™ All Purpose** and **Whole Wheat Flour**. They have given good results every time. Why trust your recipes to anything else? For variety, try the sample packet of gourmet pasta flour mixed half with Gold Medal™ for a delightful taste that will please any pasta lover.

### Pasta Measuring Cup

Use to measure flour and then the liquid. Markings on the front are for regular pasta with water, eggs and oil. Side markings are for pasta with only eggs or only water (eggs and oil are optional in pasta). Humidity varies and liquid requirements vary with different flours so it is best to hold a small amount of liquid back and see the consistency and then add the last bit of the liquid if the dough is dry.

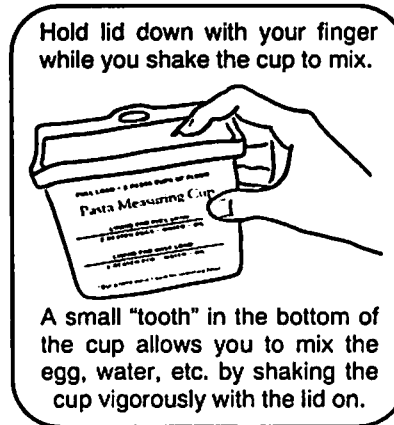

Hold lid down with your finger while you shake the cup to mix.

A small "tooth" in the bottom of the cup allows you to mix the egg, water, etc. by shaking the cup vigorously with the lid on.

### Water or Juice?

You can use spinach, carrot, tomato or just about any juice instead of water when making pasta. Because juice tends to be thicker, it may require some extra juice in the recipe. Mix as usual and watch your mixture develop in the pasta machine and add either a bit more juice, or if it gets too wet, add a bit more flour through the grates on top while the machine is on MIX.

### Cooking Pasta

Cooking pasta "al dente" [to the tooth] firm and chewy is always preferred. Don't overcook your pasta; it will become too soft and not very appealing. Some of the smaller pasta shapes such as angel hair, vermicelli and spaghetti take as little as 30 seconds to a minute or two to cook (unlike hard, dried out packaged pasta). With the fresh pasta, you can have more variety in the shapes and thicknesses of your pasta. Cook in 6 quarts of boiling water, remove immediately. Drain but do not rinse unless you are going to use it later - such as in a cold pasta salad.

We recommend that you make half loads for your first 6 batches of pasta to break in your machine.

1. Machine OFF. Lid open.

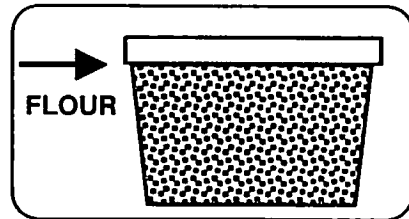

2. Fill Pasta Measuring Cup to the lid with flour. Pour this into mixing bin. Close mixing bin lid.

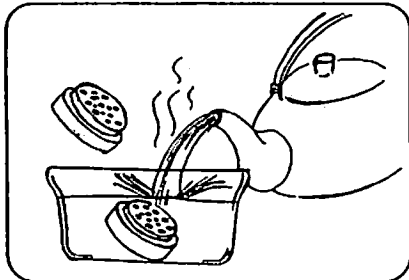

3. Select Pasta Shaping Die you want to use. Set it in very hot water for a minute.

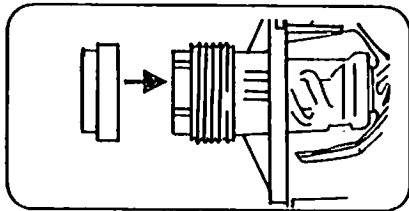

4. Put the warm die on the front of machine and secure it with the locking ring.

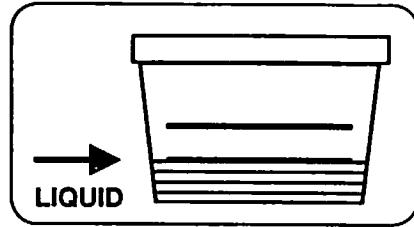

5. In Pasta Measuring Cup:  
1 Egg (Optional)  
1/2 Teaspoon Salt (Optional)  
1 Tablespoon Olive Oil  
Water (or juice) filled to HALF LOAD line.

Beat mixture with a fork or shake vigorously with Pasta Measuring Cup lid closed.

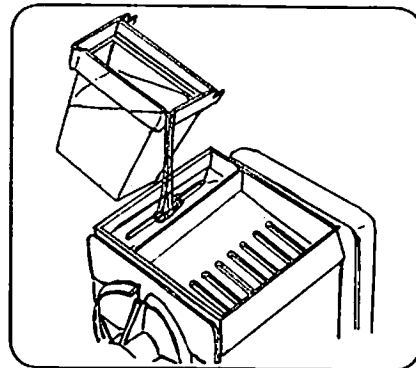

6. Switch to MIX and slowly pour the liquid back and forth through the slot in lid. Mix for a minute. Pasta dough should be evenly mixed with small lumps. Not powdery (too dry) and not in one large wet lump (too wet).

7. Turn OFF and let machine completely stop. *Never switch from MIX to EXT or from EXT to MIX without stopping first.*

Nuestra máquina ha sido diseñada para facilitar su uso (y limpieza), es eficiente y tiene un motor potente. Es la máquina de más alta calidad para hacer pasta, que actualmente está disponible para uso en el hogar.

Pruebe su creatividad. Disfrute de esta máquina y diviértase.

## INSTRUCCIONES DE ENSAMBLAJE

Para su seguridad apague y desenchufe la máquina.

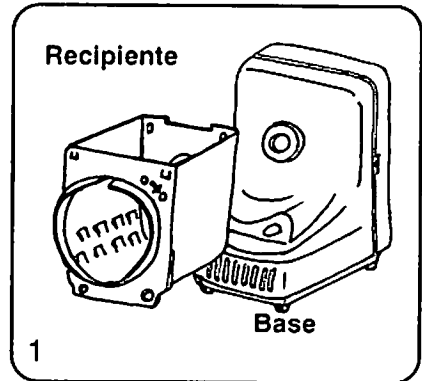

Coloque el recipiente de mezclar firmemente sobre la base (cerciórese de que quede bien sujetado). La máquina no funcionará si el recipiente de mezclar no está colocado adecuadamente.

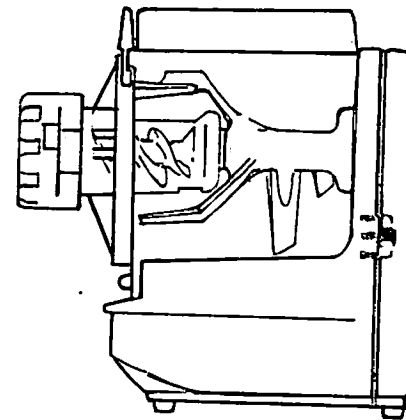

Interruptor de Retraso (Switch Delay):

Esta unidad viene equipada con un interruptor de retraso que tarda un segundo en activar el motor. Esta función extiende la duración y seguridad de su máquina para hacer pasta.

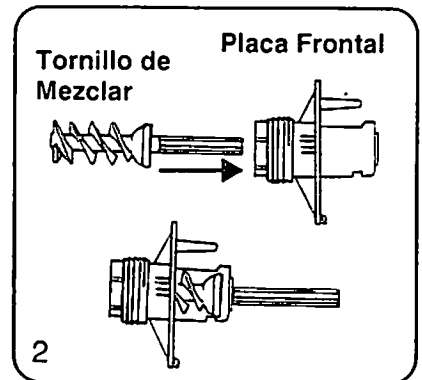

Instale el tornillo de mezclar a través de la placa frontal.

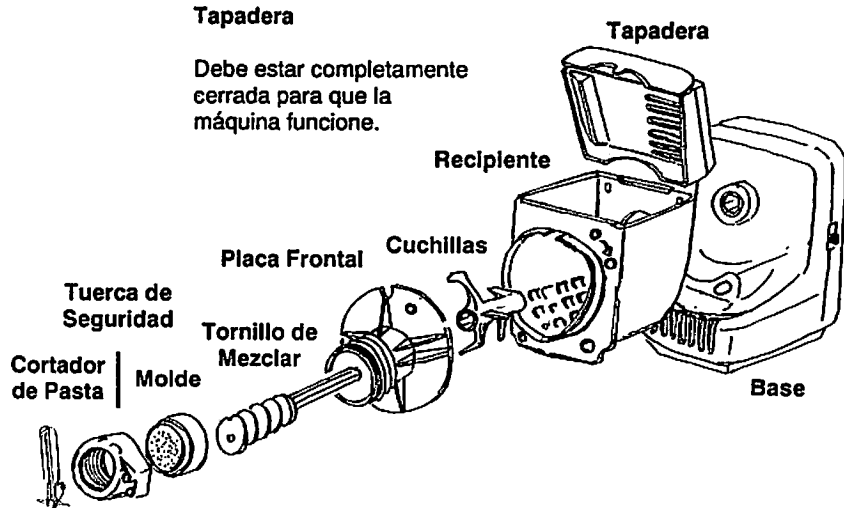

**Tapadera**

Debe estar completamente cerrada para que la máquina funcione.

**Tapadera**

**Recipiente**

**Placa Frontal**

**Cuchillas**

**Tuerca de Seguridad**

**Tornillo de Mezclar**

**Base**

**Cortador de Pasta**

**Molde**

**Cortador de Pasta**

Se usa para cortar la pasta al tamaño adecuado.

**Molde de Pasta**

La masa pasa por éste para formar la pasta.

**Tornillo de Mezclar**

Mezcla la masa forzándola por las cavidades del molde de pasta.

**Cuchillas**

Mezclan la masa y después la empujan hacia el frente durante la extracción (empujándola a través de un molde).

**Base**

Sostiene el recipiente de mezclar y contiene el motor.

**Recipiente**

Sostiene la masa para la pasta.

**Tuerca de Seguridad**

Asegura el molde para pasta en su posición.

**Placa Frontal**

Sujeta al tornillo de mezclar, el molde y la tuerca de seguridad.

Por favor lea todas las instrucciones y advertencias antes de operar esta máquina.

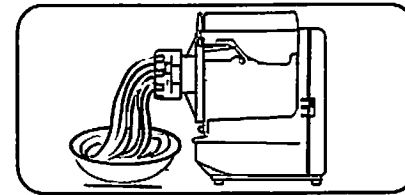

**8.** Turn machine on EXT (extrude) and watch your pasta come out the front. Cut it off at desired lengths with the cutter (or a table knife).

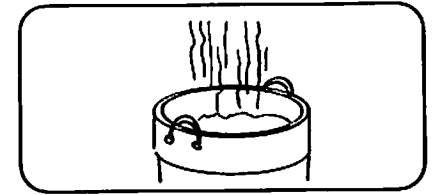

**9.** Cook fresh pasta in at least 6 quarts boiling water. Drain and serve with sauce. Angel hair cooks in 30 seconds. Spaghetti in 1 minute. *Do not overcook.*

**HALF LOAD (Serves 2 -4)**

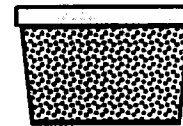

**FLOUR**

1 Pasta Measuring Cup

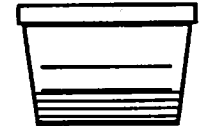

**LIQUID**

1 beaten egg, 1/2 t salt, 1 T oil and water to HALF LOAD line.

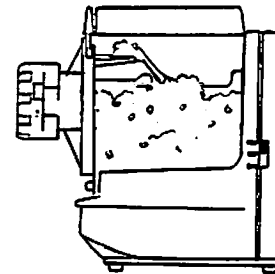

**Just Right -**

Well mixed. Small pea-sized lumps. Easy to get the correct mixture if you hold a tiny bit of the liquid back until you see how the pasta dough develops (about 1 minute).

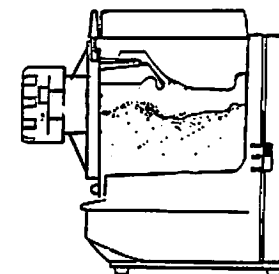

**Too Dry -**

Still powdery. Just add liquid (water or juice) by teaspoonful while machine is on MIX. Watch for the small lumps to appear.

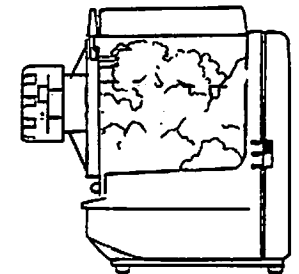

**Too Wet -**

Large wet lumps sticking to blades? Add flour while machine is on MIX until you have small lumps. You may have to stop machine and take dough off blades.

Your Popeil Automatic Pasta Maker™ has been designed to be easy to use and easy to clean. Be creative and develop new recipes that include your favorite spices and flavorings. Here are a few tips that will help:

Let your machine rest two minutes between loads.

**You can reuse the dough.**  
If you want to put the dough into another shape, just put it back in the mixing bin and run it through again. You may need to adjust the mixture with either a bit more water or flour to get the right consistency. (Don't do this with dry dough.)

### Storing Pasta

Fresh pasta can be frozen for 6 months or refrigerated for a few days. It stores best if first left to dry (about an hour) so the pasta doesn't pack together.

### Cutting Pasta

You can also use a kitchen knife or extrude long lengths, let them dry a bit and cut them with scissors.

### Pasta Sticking Together?

Probably too wet so add flour (See page 9). Keep the strands of pasta separate as they come out. Use your hand to gently ruffle the strands in front of the fan drier while extruding.

### Full Load (Serves 4 - 6)

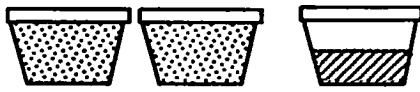

<i>In mixing bin:</i>	<i>Turn to MIX and slowly add liquid:</i>
<b>2 Pasta Measuring Cups Flour</b>	<b>2 Beaten Eggs</b>
	<b>1 t Salt</b>
	<b>2 T Olive Oil</b>
	<b>Water or Juice (to FULL LOAD Line)</b>

### Half Load (Serves 2 - 4)

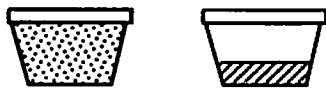

<i>In mixing bin:</i>	<i>Turn to MIX and slowly add liquid:</i>
<b>1 Pasta Measuring Cup Flour</b>	<b>1 Beaten Egg</b>
	<b>1/2 t Salt</b>
	<b>1 T Olive Oil</b>
	<b>Water or Juice (to FULL LOAD Line)</b>

**Never turn machine to EXT (extrude) before flour and liquid are well mixed.**

## Reglas de Seguridad Importantes

Al usar aparatos electrodomésticos, siempre se deben seguir las precauciones básicas de seguridad, incluyendo las siguientes:

1. Lea todas las instrucciones antes de usar la máquina.
2. Para protegerse de las descargas eléctricas, nunca sumerja en agua u otro líquido, la base, el ensamblaje del motor u otras partes eléctricas.
3. Cuando un niño use esta máquina o esté cerca de ella, es necesaria la supervisión de un adulto.
4. Desconecte la máquina cuando no esté en uso, antes de armar o desarmar las partes o antes de limpiarla.
5. Evite el contacto con las partes que están en movimiento. Mantenga el cabello y joyería fuera del alcance de la máquina.
6. No opere ningún aparato electrodoméstico si el cordón eléctrico o el enchufe están dañados, después de que la unidad tiene una falla mecánica, se cae o se daña en forma alguna. Envíe la máquina a Popeil Pasta Products, Inc. para examen, reparación o ajuste eléctrico o mecánico.
7. El uso de aditamentos que no son recomendados o vendidos por Popeil Pasta Products, Inc. puede ser peligroso.
8. No se use al aire libre.
9. No deje que el cable eléctrico cuelgue sobre la orilla de una mesa o mostrador, ni que esté en contacto con superficies calientes.
10. Mantenga las manos, cabello, joyería, ropa, al igual que espátulas y otros utensilios u objetos extraños, lejos del recipiente cuando la máquina Pasta Maker esté funcionando, para reducir el riesgo de lesión a personas y/o daño de la máquina.
11. Remueva todas las piezas antes de lavar la cubierta.
12. Siempre opere la máquina con la tapa bien cerrada.
13. Asegúrese de poner el botón en la posición de apagado "OFF" después de cada uso y asegúrese de que el motor haya parado completamente antes de quitar cualquier pieza de la máquina.
14. Usela únicamente en tomas de corriente de 120 voltios A/C.
15. No trate de anular el mecanismo de seguridad de la tapa.
16. Este aparato no debe usarse en cualquier otra forma que no sea la indicada.

**ÚNICAMENTE PARA USO DOMÉSTICO  
GUARDE ESTAS INSTRUCCIONES.**



*Cleaning your Popeil Automatic Pasta Maker™ is easy. After making pasta just follow these steps:*

*All of the parts are dishwasher safe except the base which houses the motor. Wipe the base unit clean with a soft damp cloth.*

**To disassemble remove lid first**

1. Unplug the machine, take it apart, remove any lumps of dough and let it dry out for easier cleaning.

2. If the Locking Ring cannot easily be removed, run the machine on MIX for a moment to relieve pressure on the die and then use the Wrench to remove the Locking Ring.

3. Remove excess dough from the dies and let them dry out on a window sill or freeze them. Use the pick to remove dried dough (or try knocking them on a counter top and the dough often falls out).

4. Put all pieces except the motor base in the dishwasher.

5. It is important to prevent flour or dough from building up in the hole at the back of the base.

6. Keep the air and fan vents in the front free of any flour or contaminants. If something should get in there, hold the unit with the vents facing down and gently shake out any flour.

7. Use the small cleaning brush to keep the threads of the Face Plate and Locking Ring clean.

CUT OUT, FOLD AND MAIL IN AN ENVELOPE TO:

**Popeil Pasta Products, Inc.  
Warranty Registration Dept  
5308 Derry Avenue, Suite A  
Agoura Hills, CA 91301-9887**

CUT HERE →

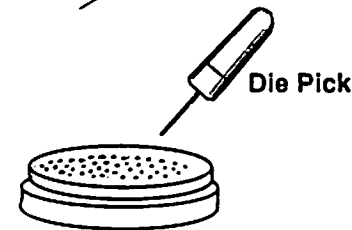
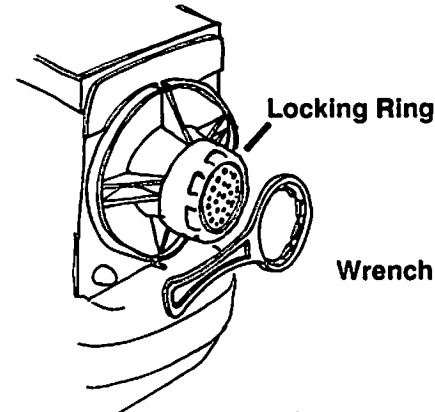

**If flour gets inside vents, hold upside down and gently shake**

To avoid problems with your Popeil Automatic Pasta Maker™, be sure to read all the Safeguards, Cautions and Instructions in this booklet. Here are the solutions to common problems:

## Machine Won't Start

Be sure:

- It is plugged in
- Lid is securely latched
- Mixing bin is all the way back against the base

## Switch Delays Starting

The 1 second delay is a feature that has been included to provide years of longer life for your machine.

## Cleaning Problems

It's easier to clean the parts after you have removed any excess dough and let them dry.

## Slow Extruding Pasta

Dough needs to be the correct consistency. See *How to Make Fresh Pasta Section*. Set the die in very hot water for a minute prior to making pasta. You can always correct your pasta by putting it back into the mixing bin and starting over.

## Can't Remove Locking Ring

Switch to MIX for a few seconds. This will relieve pressure

on the Locking Ring and die. Use the Wrench to help unscrew the Locking Ring.

## Machine Noises

Extruding is usually louder than mixing. But loud clunks and squeaks are not normal. Stop and be sure your machine is assembled correctly. Also see the *Cleaning Section* to be sure it is clean.

## Friction -Steam from the Die

Some steam escaping from the pasta die is normal particularly with the Angel Hair die. Don't touch dies when they are hot after extruding.

## Electrical Problems

If you ever detect smoke, burning smells, or any electrical problem, unplug the machine and return it as instructed in the Warranty.

## Pasta doesn't come out evenly

Put die in hot water just prior to making pasta and coat back of it with vegetable oil.

# Warranty Registration Card

To register ownership, please fill out the following information, cut the page along dotted line and mail it in an envelope to Popeil Pasta Products, Inc.

**IMPORTANT: MAIL THIS CARD  
(OR YOUR WARRANTY WILL NOT BE ACTIVATED)**

DATE OF PURCHASE \_\_\_\_\_

SERIAL NUMBER \_\_\_\_\_

NAME \_\_\_\_\_

ADDRESS \_\_\_\_\_

CITY \_\_\_\_\_ ST \_\_\_\_\_ ZIP \_\_\_\_\_

PHONE # \_\_\_\_\_

PURCHASED FROM: \_\_\_\_\_

PURCHASE PRICE: \_\_\_\_\_

MODEL PURCHASED: \_\_\_\_\_ PASTA MAKER \_\_\_\_\_

PASTA MAKER WITH UPSELL \_\_\_\_\_

To order extra items, please contact (800) 486-1806 between 8:30 a.m. and 5:00 p.m. Pacific Standard Time

**SIX MONTH LIMITED WARRANTY**

Popeil Pasta Products, Inc. warrants to the original owner of this product that it is free from defects in material and workmanship for a period of six months from date of purchase providing the Owner Registration Card has been completed and returned to Popeil Pasta Products, Inc. within thirty (30) days from the original purchase date.

The manufacturer's obligation shall be limited to repairing or replacing F.O.B. Agoura Hills, CA 91301 any part of the product which is defective. Such warranty shall not apply to defects resulting from tamper, cosmetic damage, acts of God, accidental breakage, abuse, negligence, neglect or misuse.

If you must return the product for reasons of malfunction within the six month warranty period, the following action and steps are required:

1. The machine must be clean and packaged securely to protect from damage or breakage in shipment.
2. Call and obtain a RETURN AUTHORIZATION NUMBER. Then ship prepaid to Popeil Pasta Products, Inc. by the most convenient method. Enclose \$17.90 to cover return shipping, handling and insurance. Popeil Pasta Products, Inc. will repair or replace your pasta machine and return it to you prepaid.
3. If you return the product after the six month warranty period, enclose \$45.00 plus \$17.90 for shipping handling and insurance and Popeil Pasta Products, Inc. will replace/repair your machine and return it to you prepaid.

Even if not required, the rights in this warranty are granted to you. This warranty gives you specific legal rights, and you may also have other rights which vary from state to state. Return of owner registration card is not a condition precedent to warranty coverage.

Popeil Pasta Products, Inc. will not be held liable for any special, incidental, or consequential damage, resulting from possession, use or loss of use of this product either directly or indirectly.

No returns will be accepted without prior authorization. TO RECEIVE A RETURN AUTHORIZATION NUMBER call Popeil Pasta Products, Inc. Customer Service Dept.

**POPEIL PASTA PRODUCTS, INC.**

5308 Derry Avenue, Unit A • Agoura Hills, CA 91301 • (818) 706-1806

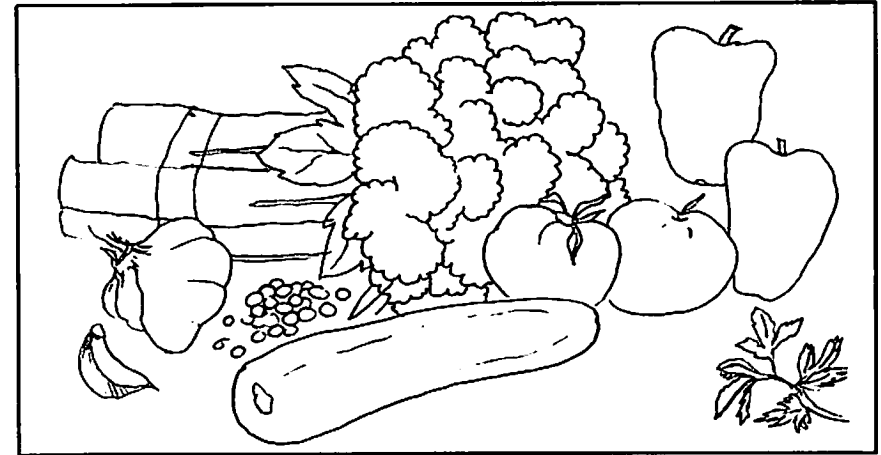

**Pasta Primavera**

Select the pasta you want for this dish. The sauce is light, and it is best to use a lighter pasta such as Fettuccine, Linguine, Vermicelli, Fusilli, Angel Hair or Spaghetti.

- 8 Tablespoons Olive Oil
- 2 Pasta Measuring Cups Vegetables (Diced, Chopped, Sliced or use Frozen Vegetables)
- 1 Tablespoon Garlic, Finely Chopped
- 2 Tablespoon Italian Herbs

(If you use frozen or dehydrated vegetables, add them to your boiling pasta water). As soon as it returns to a boil, add your fresh pasta and cook quickly (usually 1-2 minutes).

Sauté garlic in olive oil and add herbs. Drain pasta and add olive oil/garlic/herb mixture. Gently mix with vegetables and serve with Parmesan cheese, salt and pepper to taste.

Great idea: Chop (or coarsely grate) 1 zucchini, 1/2 cup broccoli, 1/2 cup cauliflower, 1 carrot; add diced: 1/2 green bell pepper, 1/2 red bell pepper. This makes a colorful and healthful dish.

**Two-Minute Clam Sauce for Linguine**

Pasta: Linguine, Angel Hair, Spaghetti, or any light pasta

- 3 Tablespoons Olive Oil
- 2 Tablespoons Garlic, Finely Chopped
- 1 Can of Clams with Juice
- 3 Tablespoons Oregano
- Fresh Ground Pepper (To Taste)
- Crushed Red Pepper
- 1/2 Cup White Wine (Optional)
- 1/2 Cup Prepared Pasta Sauce (Optional)

Sauté garlic and clams in olive oil. Add oregano, pepper and crushed red pepper to taste. If desired, add white wine and/or prepared pasta sauce. Pour over pasta, garnish with minced parsley.

**Tagliatelle & Chicken**  
(Chicken & Noodles)

Pasta: Tagliatelle or Egg Noodles (with 2 Tablespoons Olive Oil or Butter)

- 4 Large or 6 Small Pieces of Boned Chicken Cut In Chunks
- 2 Tablespoons Garlic, Finely Chopped
- 2 Tablespoons Italian Seasoning
- 2 Tablespoons Parsley
- Olive Oil
- Salt & Pepper
- Parmesan Cheese

Bake or sauté chicken in olive oil with garlic and seasoning until done. Pour chicken over freshly cooked tagliatelle and serve hot. For variety, add sautéed mushrooms and/or bell peppers.

**Chocolate Dessert Pasta**

Pasta: Angel Hair, Spaghetti, Fettuccine, Vermicelli or Linguine.

Before starting, gently coat kneading screw with olive or vegetable oil to prevent the machine from "squeaking" when mixing the cocoa.

- |                |                             |
|----------------|-----------------------------|
| In mixing bin: | 1 Pasta Measuring Cup Flour |
|                | 1/4 Standard Cup Cocoa      |
|                | 1/2 Standard Cup Sugar      |
|                | 1/2 Teaspoon Salt           |

- |         |                      |
|---------|----------------------|
| Liquid: | 1 Tablespoon Vanilla |
|---------|----------------------|

Add the liquid ingredients to Pasta Measuring Cup. Fill to "Half Load" line with water or chocolate syrup.

Place dry ingredients in mixing bin. Turn machine on MIX. Gradually add liquid. Mix about one minute until dough is uniform. If too wet, add flour through top grate by tablespoonful. If too dry, add water or chocolate syrup through liquid slot by teaspoonful. Extrude and cook 1 to 2 minutes.

Serve warm and top with any combination of the following:

- Chocolate Syrup
- Fresh Strawberries and Cream
- Coconut
- Raspberry Syrup
- Marshmallow Cream
- Chopped Nuts



Bagels

- 1 Package Quick Rise Yeast
- 1 1/2 Pasta Cups of Flour
- 1 Teaspoon Salt
- 1 Tablespoon Sugar
- 3 Tablespoons Oil
- 2/3 Cup Water
- 1 Beaten Egg

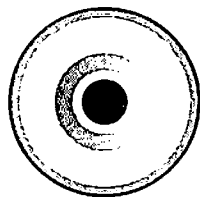

Put on the bagel die.

In the mixing bin place yeast, salt, sugar and half of the flour. Warm oil and water to 125°-130°. Slowly add oil and water mixture to mixing bin while machine is turned on to MIX. Add beaten egg and continue to mix.

Add remaining half of flour as needed to keep mixture dry enough to properly extrude. You may need to stop machine and pull dough off the blades and dust with flour. Then continue to extrude bagels.

Cut off about 6" long. Shape into circles and let rise (covered and warm) for 1-2 hours until almost doubled in size.

Bring 6 quarts of water with 4 tablespoons salt in it to a boil. Boil 4 bagels at a time for 6 minutes (3 minutes per side). Remove from boiling water, drain and place on a greased baking pan.

If you want tops extra brown you can now: A. Put under a broiler for 5 minutes or B. Brush with egg yolk and now is also the time to add toppings (poppy seeds, sesame seeds, onion bits, etc.)

Bake on greased baking sheet at 375° for 30 to 35 minutes. (If broiled, bake bagels for 25 minutes.) Cool before serving.

Marinara Sauce

- 1 Large Onion Diced
- 2 Cloves Garlic (Pressed)
- 2 Tablespoons Italian Seasoning
- 3 Pasta Measuring Cups Diced Tomatoes  
(or 2 16-oz cans of Tomato Sauce)
- 4 Tablespoons Olive Oil

Sauté onion and garlic in olive oil. Add Italian seasoning and tomato mixture and simmer for 2 hours. Pour over fresh pasta.

For variety add: 1 cup of sautéed mushrooms and/or 1 can sliced black olives. Yields 1 quart. Serves 6.

Spinach Fettuccine in Creamy Dill Sauce

Pasta - Fettuccine, Tagliatelle, Linguine, Rigatoni or Shells  
Great with any pasta, but this is very tasty with spinach pasta!

Make your liquid for the pasta with fresh spinach juice or mix spinach with a small amount of water in a blender and strain before adding to the egg and oil mixture.

- 1 Tablespoon Butter
- 1 Teaspoon Garlic, Finely Chopped
- 1 Cup Heavy Cream
- Salt & Pepper (To Taste)
- 1/4 Cup Parmesan Cheese
- 2 Tablespoons Fresh Dill
- 1/2 Cup Diced Tomatoes

Melt butter with garlic in pan. Add cream, salt, pepper, Parmesan cheese. Stir until cheese is melted. Reduce heat, add fresh dill and diced tomatoes. Remove from heat and gently pour over pasta.

Pasta with Sun Dried Tomatoes & Pine Nuts

Pasta: Angel Hair, Vermicelli, or Linguine

- 1/4 Cup Olive Oil
- 1 Clove Garlic, Finely Chopped
- 2 Tablespoons Italian Herbs
- 1/4 Cup Sun Dried Tomato Pieces
- 1/4 Cup Pine Nuts

Sauté garlic in olive oil, add herbs, remove from heat, add sun dried tomatoes (cut tomatoes in 1/8" slices). Toss lightly with cooked pasta. Top with pine nuts. Serve with Parmesan cheese.

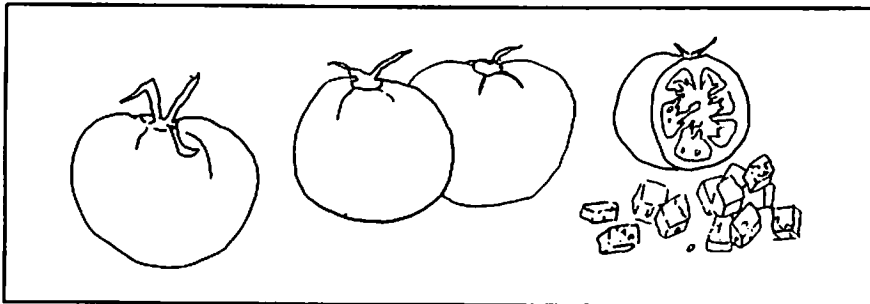

Basic Pasta with Fresh Tomatoes

Pasta: Any of your favorites

- 6 Tablespoons Olive Oil
- 2 Tablespoons Minced Garlic
- 2 Tablespoons Fresh Basil, Minced
- 1 Cup Diced Fresh Ripe Tomatoes
- Salt & Pepper
- Parmesan Cheese

Sauté garlic. Add basil to hot skillet. Remove from heat and stir in fresh diced tomatoes. Pour lightly over fresh pasta. Serve with Parmesan cheese.

Peanut Butter Cookies

- 2-1/2 Cup Flour
- 1 Teaspoon Baking Soda
- 1/2 Teaspoon Salt
- 1 Cup Sugar
- 1/2 Cup Brown Sugar
- 1 Cup Peanut Butter
- 1/2 Cup Butter
- 2 Tablespoons Vanilla
- 2 Eggs

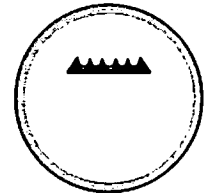

Cookie

Sift flour, soda and salt into mixing bin. Add sugar. Mix dry ingredients for a minute in machine fitted with the large cookie die.

Stop machine. Open lid and add remaining ingredients (peanut butter, butter, eggs and vanilla). Close and MIX about one minute, then extrude.

If cookie dough stops coming out or slows down, it may be necessary to add more flour - 1 tablespoon at a time (through grate in the lid) to keep dough surface dry enough to drop down into extruder. Cook 375° for 10-12 minutes.

Butter Cookies

- 1 Pasta Measuring Cup All Purpose Flour
- 1/2 Cup Sugar
- 1/2 Teaspoon Salt
- 1/2 Cup Melted Butter
- 1 Teaspoon Vanilla

Fit machine with large or small cookie die. Mix dry ingredients in machine bowl. Add rest of ingredients while mixing. Extrude. Cut into 2" pieces or desired length. Sprinkle with a little sugar before baking. Bake 375° 8-10 minutes.

### Hungarian Paprika Pasta

To a regular full load of pasta add 2 tablespoons of paprika to the liquid and stir well before adding to the flour as it mixes.

### Summer Fruit Pasta

In a blender liquefy or juice fresh fruit such as strawberries, lemon, peaches (peeled) or blackberries. Add 1/2 cup sugar to 2 Pasta Measuring Cups of flour and Mix. Then add enough of the fruit mixture to bring the liquid measure to the Full Load Line on the mixing cup. Cook as usual and serve with additional fresh fruit.

### Garlic Pasta

Add 2 garlic (crushed, or pureed) to the liquid in a full load of pasta. Cook and serve with sauce and cheese.

### Salmon Mousse

- 1 14 oz -16 oz Can of Sockeye Salmon
- 1 8 oz Package of Cream Cheese
- 1 Teaspoon Salt
- 3 Tablespoons White Prepared Horseradish
- 1 Tablespoon Liquid Smoke
- Optional: 1 Teaspoon Dried Dill Weed

For hors d' oeuvres, use large cookie die. Drain salmon and put in the mixing bin. Break cream cheese into chunks and add to the mixing bin. Add horseradish and salt. Turn on the machine and add the liquid smoke through the top of the machine. Mix 10 to 15 seconds before starting to extrude.

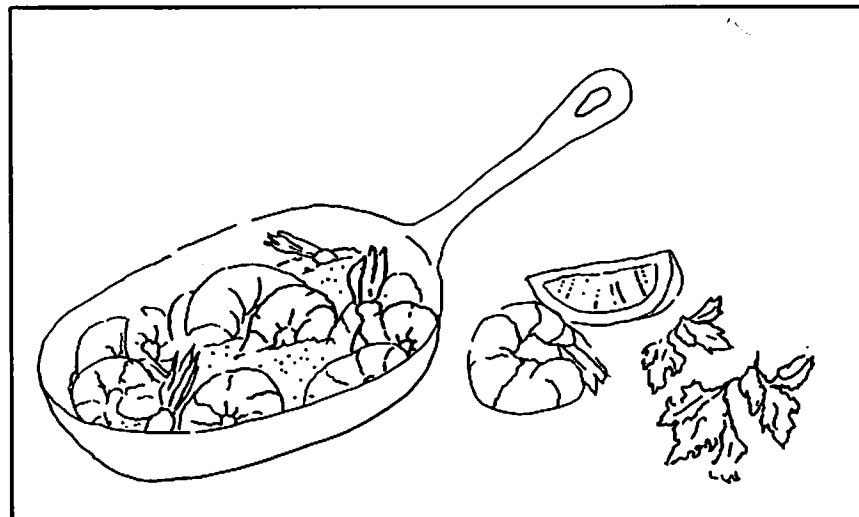

### Lemon Pepper Pasta & Shrimp

To make Lemon Pepper Pasta, add 1 tablespoon lemon juice, 1 teaspoon lemon zest and 1 tablespoon black or white pepper to one load of basic pasta. (For best results, add these to your liquid measure)

Pasta: Lemon Pepper Linguine, Spaghetti or Fettuccine

- 1/4 Cup Olive Oil
- 1 lb. Fresh Shrimp, Peeled, Deveined and Butterflied
- 2 Tablespoons Minced Garlic
- 1/4 Cup Oregano
- Fresh Ground Pepper (To Taste)
- 1 Cup Prepared Pasta Sauce
- 1/4 Cup White Wine (Optional)
- Minced Parsley

Sauté garlic and oregano in olive oil. Add shrimp and sauté until done. Add pepper, prepared pasta sauce and wine. Stir. Remove from heat and pour over pasta. Garnish with minced parsley.

**Chicken a la Shannon**

This spicy dish is perfect for a lunch of four people.

Pasta: Rigatoni, Fettuccine, Spaghetti or Penne

- 4 Tablespoons Olive Oil
- 2 Tablespoons Butter
- 2 Sliced Leeks
- 1/2 Teaspoon Crushed Hot Red Peppers
- Salt & Pepper
- 4 Boneless Chicken Breasts Halves (Cut each in quarters)
- 1/2 Cup Sun Dried Tomatoes
- 1/4 Cup Half-and-Half
- Parmesan Cheese

Melt butter in olive oil. Sauté leeks with garlic, red peppers, salt and pepper. Add chicken pieces. Saute´ until chicken is done (about 10 minutes). Reduce heat, add sun dried tomatoes and half-and-half. Pour over pasta. Top with Parmesan cheese and garnish with parsley.

**Russian Borscht Pasta**

Measure a full load of pasta (2 Pasta Measuring Cups of flour). To your liquid ingredients (2 eggs, and oil) add: Beet juice instead of water and 1 teaspoon sour salt. Served as a side dish with sour cream .

**Corn Pasta**

Replace 1/4 of your flour mixture with finely ground corn meal or corn flour. Mix before adding the liquid ingredients. Use 3 eggs, oil and water for full load of pasta. Use one of the large dies like fettuccine or rigatoni for extruding your pasta.

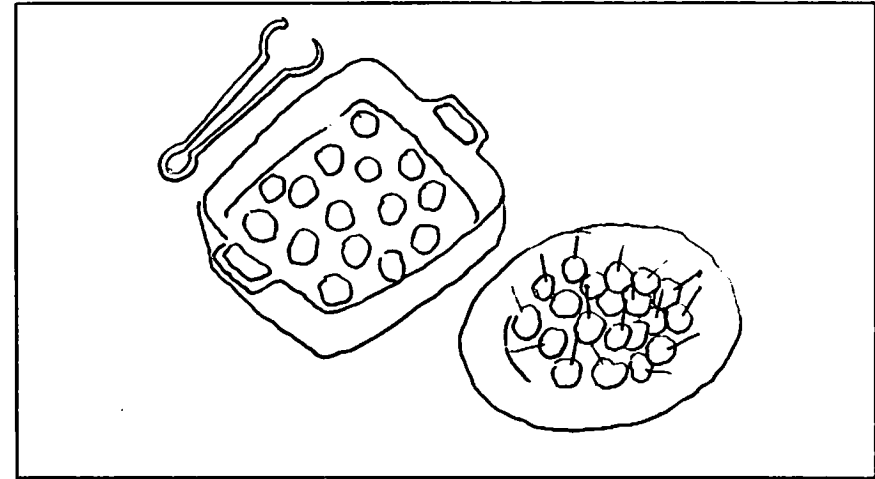

**Italian Meat Balls**

- 1 1/2 lb. Lean Ground Beef
- 1/2 Cup Finely Diced Onions
- 1 1/3 Cup Finely Diced Celery Leaves
- 2 Tablespoons Finely Diced Green Pepper
- 1 Teaspoon Salt
- 1 Tablespoon Dry Italian Seasoning
- 1 Clove Pressed Garlic
- 3 Cups Bread Crumbs
- 2 Beaten Eggs

Die: Bagel & Meatball

Put ground beef, salt, pepper, spices, celery, onion, green pepper and about 1 cup of bread crumbs in the mixing bin of the machine.

Mix lightly. Add eggs and extrude. Add bread crumbs by tablespoon through the top grates as needed to keep the meat extruding and from bunching up around the blades. Extrude 1 1/2" pieces and roll into a ball. Saute´ in a pan with 2 tablespoons of olive oil until browned. Add Spaghetti Sauce and simmer on low for 30 minutes.



Gnocchi

Use Gnocchi die on your pasta maker

- 1 Lb. Cooked Potatoes -Riced or mashed
- 1/4 Teaspoon Pepper
- 1 Teaspoon Salt
- Pinch of Nutmeg
- 1 Cup Flour (+ additional flour as needed when mixing)
- 2 Tablespoons melted Butter

Put potatoes, pepper, salt, nutmeg and flour in mixing bin and mix for one minute. Slowly add butter.

Add additional flour 1 tablespoon at a time to keep the dough extruding. Cut into 1 inch pieces.

Because this is a thicker pasta (dumpling), it will take longer to cook. Cook in 6 quarts of boiling water. Test for firmness (about 5 minutes)

Using instant potatoes:

- 1 Cup Flour
- 1 Cup Instant Mashed Potatoes
- 1 Tablespoon Salt
- 1 Egg
- 2 Tablespoons melted Butter or Oil

Mix dry ingredients in machine. Add egg, butter and hot water or hot milk to fill batch line to dry ingredients. May need to add more hot liquid 1 teaspoon at a time depending on humidity.

If necessary, return the first few inches extruded back into the mixing bin. until the pasta is coming out fairly smooth.

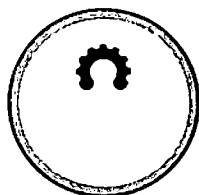

Gnocchi

Ron's Meat Sauce for Pasta

Pasta: This is a good hearty sauce for any pasta, although it may overpower the light pastas such as angel hair.

- 1/4 Cup Olive Oil
- 1 lb. Very Lean Ground Beef
- 1/4 Cup Chopped Onions
- 1/4 Cup Green Peppers, Diced
- 1 Teaspoon Salt
- 1 Teaspoon Oregano
- 1 1/2 Cups Prepared Pasta Sauce - such as Prego
- 1/4 Cup Red Wine (Optional)
- Parmesan Cheese (Optional)
- Minced Parsley

Sauté onions and green peppers in olive oil, brown hamburger then add salt, oregano and prepared pasta sauce. If desired, add red wine. Top with Parmesan cheese and garnish with minced parsley.

Artichoke & Butter Pasta

For a full load use 2 Pasta Measuring Cups of flour. Fill liquid to "Full Load" line with: 2 eggs, 2 tablespoons melted butter and fill to top of liquid line with liquefied (puréed) artichoke heart (cooked, or cooked and marinated) after straining artichoke juice through sieve. Serve with remaining artichoke hearts.

Southwest Chili Pasta

Use either all-purpose or semolina flour. For your liquid, use: 2 eggs, 1 teaspoon oil, 1 tablespoon chili powder, 1 teaspoon salt, 1 teaspoon onion powder and fill with tomato juice to top of liquid line on Pasta Measuring Cup.

### Creamy Tomato and Basil Sauce

Pasta: Any of the selections that come with your machine will work with this basic sauce.

- 5-6 Roma Tomatoes
- 4 Tablespoons Fresh Basil Leaves (Chopped)
- 1/2 Teaspoons Garlic(Minced)
- 3 Tablespoons Cream
- Basil Leaves, Minced or Whole
- Salt and Pepper
- 1/4 Cup Parmesan Cheese
- Minced Parsley
- Chopped Tomatoes

Purée tomatoes and add minced basil leaves. Put this mixture in a sauce pan. Then add minced garlic, cream and chopped or whole basil leaves, salt and pepper to taste. Pour over pasta and garnish with parsley and chopped tomatoes.

### Spicy Cajun Pasta

To your flour mixture add 1 teaspoon red chili powder, 1 teaspoon onion powder, 1 teaspoon paprika.

### French Champagne Pasta

Simply use champagne instead of water when adding the liquid to the egg/oil mixture. Can also be made with port wine for a stronger taste.

### Sour Cream & Onion Pasta

To your flour add 1 tablespoon onion powder. To your liquid add 2 tablespoons of sour cream to the egg/oil/water mixture to bring it to the "Full Load" line on your Pasta Measuring Cup. Be sure to add salt.

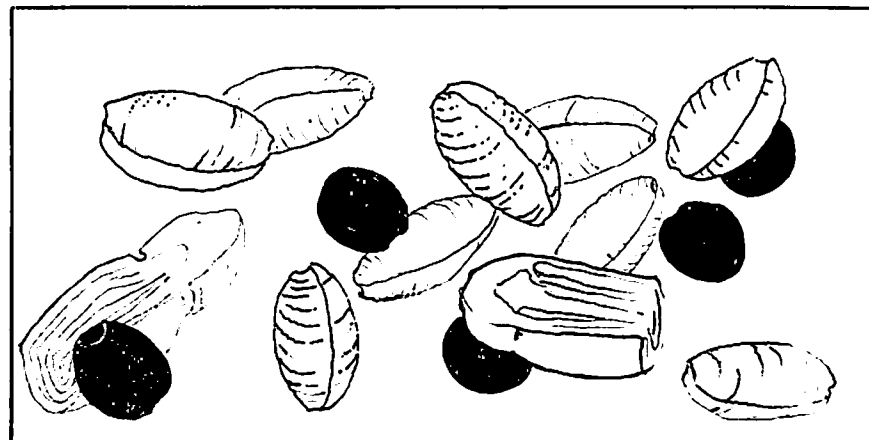

### Cold Curry Pasta Shell Salad with Artichoke Hearts and Black Olives

For a summer salad, buffet or picnic, this dish always gets great reviews!

Pasta: Curry Shells, Rigatoni or Penne Pasta

To make Curry Pasta add 4 teaspoons of curry powder and 1/2 teaspoon chili powder (optional) to your pasta liquid and then make fresh pasta as usual.

- 4 Teaspoons Curry Powder (Added to Pasta Mix )
- 1 Cup Artichoke Hearts
- 1 Cup Pitted Whole Black Olives
- 2 Tablespoons Chives (Chopped)
- 2 Tablespoons Scallions (Minced)
- 1/2 Cup Diced Tomatoes
- Salt & Pepper

Make your pasta with curry powder, cook it *al dente* and drain. Mix your dressing ingredients and toss lightly with the pasta. May be served immediately or chilled and served as a cold pasta salad.

**THIS APPLIANCE HAS A POLARIZED PLUG (ONE BLADE IS WIDER THAN THE OTHER).**

**TO REDUCE THE RISK OF ELECTRIC SHOCK, THIS PLUG WILL FIT IN A POLARIZED OUTLET ONLY ONE WAY. IF THE PLUG DOES NOT FIT FULLY IN THE OUTLET, REVERSE THE PLUG. IF IT STILL DOES NOT FIT, CONTACT A QUALIFIED ELECTRICIAN.**

**DO NOT MODIFY THE PLUG IN ANY WAY.**

Your new Popeil Automatic Pasta Maker™ is very easy to clean up—just disassemble it and let the pasta dough dry out overnight

# Really Easy Clean Up

## Let the dough dry out and fall off

Remove any excess lumps of dough and let the machine parts dry out overnight. The dough just falls off. You can then put the parts but not the base unit in the dishwasher or wash by hand!

For dies: Remove excess dough from front and back then let them dry out on a window sill. After the dough has dried it easily comes out of the holes with either a sharp tap on a counter top or with the aid of the cleaning pick.

DIE PICK



### VERY IMPORTANT

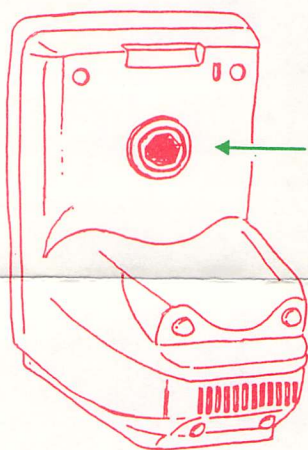

KEEP THIS HOLE FREE OF FLOUR

Be sure to keep the hole in the back of the base unit clean.

This is very important so the shaft will fit all the way in.

Read all instructions before using the machine.

If the Locking Ring cannot easily be removed, run the machine on MIX for a moment to relieve pressure on the die. Turn machine off. Then use the Wrench to remove the Locking Ring.

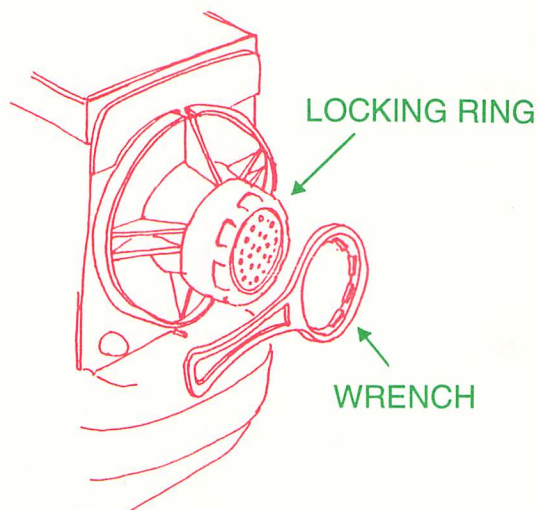



# New: Fresh Pasta in Only 3 Minutes

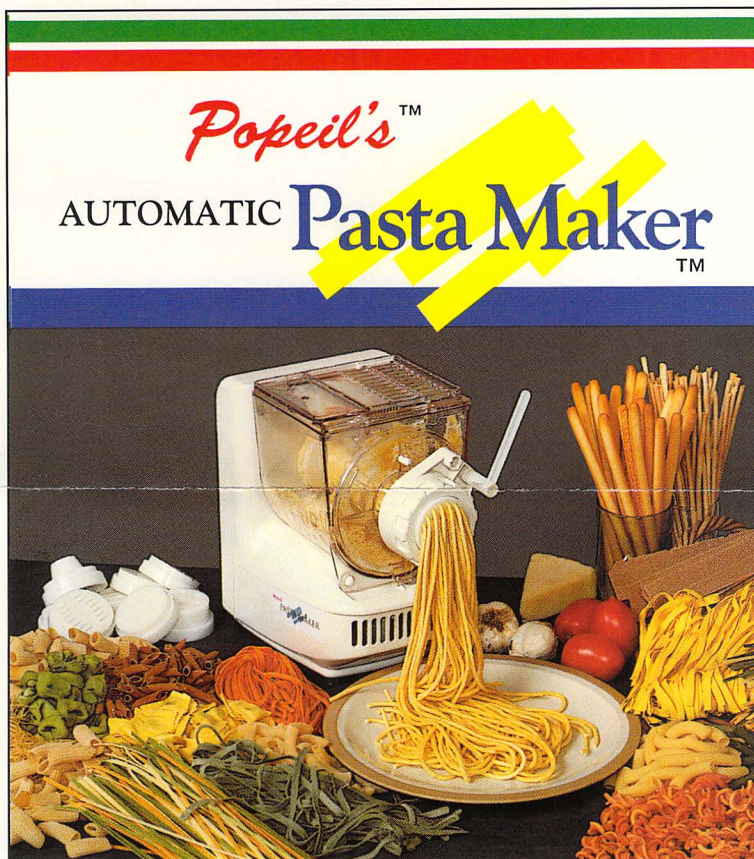

**A \$308.00 Value, For Only \$159.95**  
**Your Pasta Package Includes:**

**AS SEEN  
ON TV**

- Popeil's Automatic Pasta Maker
- 12 Shaping Dies
- Pasta Measuring Cup
- Pasta Video Instructions
- Recipe and Instruction Booklet
- Automatic Pasta Cutter
- Packet of Gourmet Pasta Flour
- Valuable Coupons
- Pasta Serving Fork

**FREE: Popeil Bagel Cutter & Bagel Knife With Order**

**Easy to use – with the Pasta Measuring Cup (included).** Just select the pasta shape (die) you want, then add liquid to the flour you measured into your machine and it automatically mixes, kneads and extrudes fresh pasta.

**Unlimited Variety.** Make standard recipes or new gourmet pastas in just minutes.

**One load feeds four.** It also has a continuous loading for parties and large families.

- **Easy to Clean - Dishwasher Safe**
- **Built-in Pasta Dryer & Pasta Cutter**

**Make Homemade Pasta: The Healthy and Economical Choice.** Once you taste fresh pasta, you won't be satisfied with the dried or canned variety! Use either all-purpose or gourmet flour.

**With 12 Shaping Dies You Can Make:**

Angel Hair	Vermicelli	Spaghetti
Linguine	Egg Noodles	Bagels
Fettuccini	Tagliatelle	Bow Tie
Macaroni	Rigatoni	Gnocchi
Lasagne	Meatballs too!	Cookies

**POPEIL PASTA PRODUCTS, INC.**  
 9457 DE SOTO AVENUE  
 CHATSWORTH, CALIFORNIA 91311  
 TELEPHONE (818) 775-4680 • FAX (818) 775-4664  
 (800) 486-1806

U.S. AND FOREIGN PATENTS PENDING COPYRIGHT © 1993 BY POPEIL PASTA PRODUCTS, INC. ALL RIGHTS RESERVED. POPEIL IS A REGISTERED TRADEMARK. POPEIL'S AUTOMATIC PASTA MAKER IS A REGISTERED TRADEMARK

## Special TV Offer

In addition to the 12 dies that come with your Popeil Automatic Pasta Maker, you get 12 more dies so you will have the complete set of 24 dies that the company makes. These additional dies are sold separately for \$9. The dies are for:

Fusilli	Oriental Noodles	Penne
Shells	Pappardelle	Rugala
Corkscrew	Small Cookies	Pastry
Manicotti	Large Bagels	Rottini
Breadsticks		

## Your Pasta Accessory Package:

- **12 Additional Shaping Dies** (Reg \$108)
- **Pasta Video Cookbook** (Reg \$30)
- **4-Way Ravioli Maker** (Reg \$12)

**A \$150 Value, Now Only \$39.95**

No additional shipping and handling! Available only for the next 30 days from your invoice or ship date.



# Popeil Automatic Pasta Maker™

## Order Form

Qty	Item	Each	Total
	Pasta Maker Deluxe Pkg 9024	\$349.95	
	Pasta Maker Pkg 9012	\$269.95	
	Pasta Maker Pkg 9008	\$199.95	
	Cleaning Brush	\$0.75	
	Die Cleaner/Pick	2/1.00	
	Face Plate	\$18.95	
	Kneading Blades	\$9.00	
	Kneading Screw	\$7.00	
	Locking Ring	\$5.00	
	Locking Ring Wrench	\$5.00	
	Mixing Bin	\$11.90	
	Mixing Bin Lid	\$10.50	
	Pasta Cutter	\$1.25	
	Pasta Measuring Cup	\$5.00	
	Pasta Serving Fork	\$2.80	
	Ravioli Maker	\$4.50	
	Rubber Legs (set of 4)	\$2.50	
	Instructional Video Tape	\$19.99	
	Instructions & Video Cookbook	\$39.99	
	Instruction & Recipe Booklet	\$3.00	
	5-Pack Variety Gourmet Flour	\$19.95	
	Flour Packet	\$1.23	
	<b>SPECIAL OFFER</b> Any Three Dies (plus SH)	\$19.95	
<b>Subtotal</b>			
<b>Total order</b>		=	
<b>Calif. residents add tax</b>		+	
<b>Shipping Charges – \$18.00 or less</b>		+	\$2.50
<b>\$18.01 – \$99.99</b>		+	\$5.90
<b>\$100.00 – \$200.00</b>		+	\$9.90
<b>Over \$200.00</b>		+	\$17.90
<b>Total this order</b>		=	

Qty	#	Pasta Dies	Each	Total
	B5	Gnocchi	\$9.00	
	B6	Vermicelli	\$9.00	
	B7	Cookie	\$9.00	
	B8	Small Bagel	\$9.00	
	D13	Macaroni	\$9.00	
	D14	Rigatoni	\$9.00	
	D15	Linguini	\$9.00	
	D16	Spaghetti	\$9.00	
	E17	Tagliatelle	\$9.00	
	E18	Lasagna	\$9.00	
	E19	Angel Hair	\$9.00	
	E20	Fettuccine	\$9.00	
	A1	Penne	\$9.00	
	A2	Rugola	\$9.00	
	A3	Pappardelle	\$9.00	
	A4	Pastry	\$9.00	
	C9	Oriental Noodle	\$9.00	
	C10	Small Cookie	\$9.00	
	C11	Rotini	\$9.00	
	C12	Breadstick	\$9.00	
	F21	Bagel & Meatball	\$9.00	
	F22	Manicotti	\$9.00	
	F23	Shell	\$9.00	
	F24	Fusilli	\$9.00	
		3-Year Extended Service Contract	\$52.00	
		<b>Total this order</b>	=	

- Check enclosed  
 Bill my  Visa  MC  
  Discover  Am Express

Acct # \_\_\_\_\_

Name on card \_\_\_\_\_

Exp Date \_\_\_\_\_

Signature \_\_\_\_\_

Ship to:

Name \_\_\_\_\_

Address \_\_\_\_\_

City \_\_\_\_\_

State \_\_\_\_\_

Zip \_\_\_\_\_

Mail this form to:

Popeil Pasta Products, Inc.  
9457 De Soto  
Chatsworth, CA 91311

Telephone (818) 775-4680  
or (800) 486-1806  
Fax (818) 775-4664